

#20-377A 55-7 Bel Air 2 Door Sedan Side Window Molding
Clip Set, INCLUDES DOOR MOLDING END CLIPS.

1. Install these moldings before glass or window channels are installed; install whisker strips on lower moldings before installing moldings.

2. Door molding end clips are bagged & labeled as to where they go, necessary screws included.

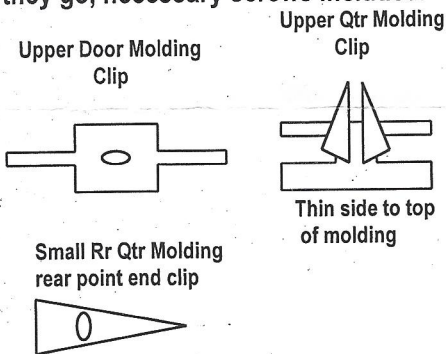

3. The Upper Door molding clip is used with the tapered head $\frac{1}{4}$ " long machine screws, these clips fit into slots of upper door molding with the raised threaded area toward hole in door.

4. The Lower Door moldings are held on only by the end clips & the small tapered head sheet metal screws supplied.

5. The Upper Qtr molding push in clip is installed in molding slots with the thinner side to the top of the molding. It is important to carefully trial fit this molding to make sure the clips line up with the holes in body correctly. In some cases it may be necessary to grind additional material from the thin side of clip to get it to fit in molding a little higher. Do this carefully with a light touch & eye protection, at most only a small amount of material will need to be removed. It is not right if you are hammering the molding onto the car.

6. The 'arrowhead' clip w/stud goes at very rear of point on Rear Molding, use with nut, flat & lock washer provided. The upper part of this molding takes 1 push in clip installed in slot the same as the Upper Qtr molding.

7. The Lower Qtr molding uses the extra bagged #20-427 on the passenger side, #20-428 on the drivers side at the very front of molding with the screw installed from inside the qtr.

8. All remaining attachment is with the tapered head sheetmetal screws provided. These go thru the small round holes in moldings into corresponding holes in body.

MADE IN U.S.A.